

Technical Data

Compressor

SECCP

Model

Designation	NLE12.6CNL 220-240V/50Hz 1~	Sales code:	105H6378
-------------	------------------------------------	-------------	-----------------

Compressor design

Oil type	Polyolester	Refrigerant(s)	R290
Oil viscosity	32cSt	Displacement	12,55cm ³ / 0,77cu.in
Oil quantity	300cm ³ / 10,1fl.oz	Compressors on pallet	80
Refr. charge - tech. limit	150g / 5,3oz		
Free gas volume comp.	2360cm ³ / 79,8fl.oz		
Weight	11,8kg / 26lbs		
Motor protection	1# internal		
Winding resistance main	5,64Ω (at 25°C)		
Winding resistance aux	8,49Ω (at 25°C)		
Max. winding temp.	125°C / 257°F		
Max. discharge temp.	130°C / 266°F		



General - Configurations with NLE12.6CNL

	Conf. 1	Conf. 2	Conf. 3
Motorconfiguration	CSIR	RSIR	RSCR
Power supply (nominal)	220-240V/50Hz	220-240V/50Hz	220-240V/50Hz
Number of phases	1	1	1
Voltage range	198-254V	198-254V	198-254V
Approvals	VDE, CCC	VDE, CCC	VDE, CCC
Starting torque	HST	LST	LST
Note	- / -		

Applications with NLE12.6CNL

	Conf. 1	Conf. 2	Conf. 3
Refrigerant	R290	R290	R290
Application	LBP	LBP	LBP
System cooling	fan 3m/s	fan 3m/s	fan 3m/s
Hot gas defrost	OK	OK	OK
Long interval pull down	OK	OK	-/-

Electrical data - Configurations with NLE12.6CNL

	Conf. 1	Conf. 2	Conf. 3
Starting device type	relay	PTC	PTC
Run capacitor	-/-	-/-	4μF
Start capacitor	80μF	-/-	-/-
LRA (locked rotor amps / 4s)	12,5A	13,4A	13,4A
RLA (rated load amps / 1s)	2,56A	2,56A	2,4A
Cut in current	12,5A	16,4A	16,4A
IP class	21	21	21

Model

Designation **NLE12.6CNL** 220-240V/50Hz 1~

Sales code: **105H6378**

Compressor dimensions

Housing	A Height	203mm / 7,99in
	B Height	197mm / 7,76in
	C Length shell	205mm / 8,07in
	D Length w. cover	254mm / 10in
	E Width	166mm / 6,54in

Connectors		Suction	Discharge	Process
		X	Y	Z
Diameter	[mm]	øi 8,11-8,29	øi 6,11-6,29	øi 6,11-6,29
	(i:inside, o:outside) [in]	øi 0,32-0,33	øi 0,24-0,25	øi 0,24-0,25
Material		copper	copper	copper
Horizontal angle	±2°	0°	0°	0°
Vertical angle	±2°	15°	21°	155°
Position l/h/w	[mm]	132/69/56	94/99/86	-111/92/72
	[in]	5,2/2,7/2,2	3,7/3,9/3,4	-4,4/3,6/2,8
Straight tube l.	[mm]	12	12	12
	[in]	0,5	0,5	0,5

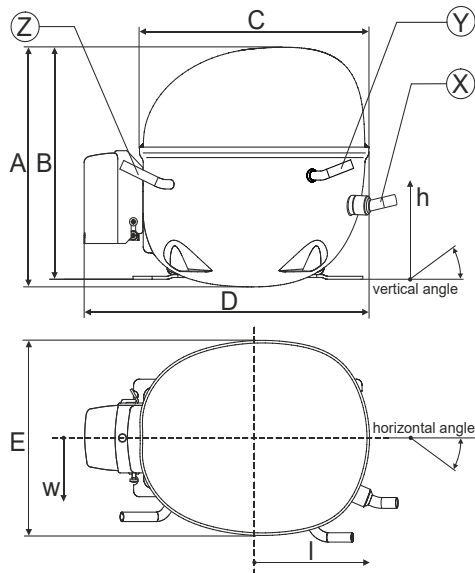

Compressor fixation

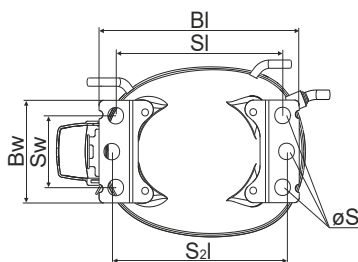

Baseplate	[mm]	[inch]
BI	204	8.03
BW	100	3.94
Small holes		
SI	170	6.7
SW	70	2.76
S2l	178	7
øS	ø 16	ø 0.63

Bolt joint

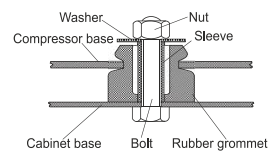

Snap-on

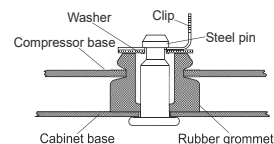

Mounting accessories

	one comp.	multi pack
Bolt joint M6 ø16mm	118-1917	118-1918
Bolt joint ø1/4" ø16mm	118-1946	
Snap-on ø7,3 ø16mm	118-1947	118-1919

Technical Data

Compressor



Model

Designation	NLE12.6CNL 220-240V/50Hz	Conf. 1	Sales code:	105H6378
-------------	---------------------------------	---------	-------------	-----------------

Configuration

Motorconfiguration	CSIR
Power supply (nominal)	220-240V/50Hz 1~
Refrigerant	R290
Application	LBP
Voltage range	198-254V
Starting torque	HST
Approvals	VDE CCC

Electrical accessories / wiring diagram

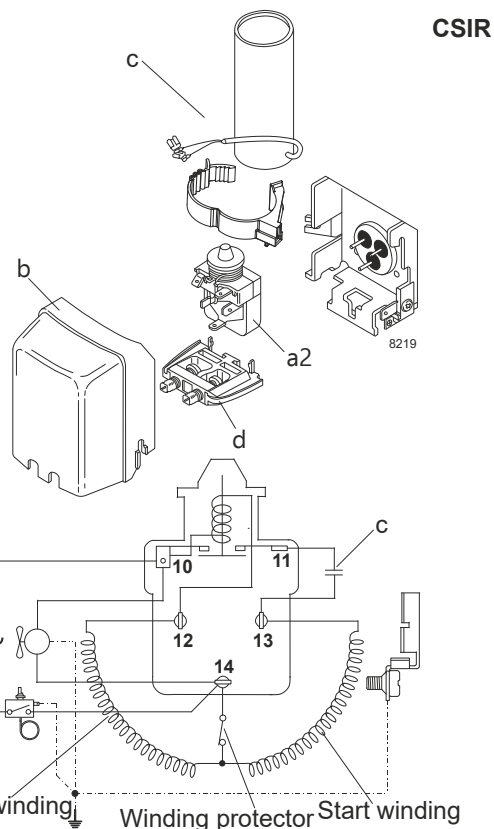

Ambient temperatures / system cooling

Ambient temperature min.:	10°C / 50°F
Ambient temperature max.:	43°C / 110°F

System cooling (n/a: outside limits)			
T ambient	LBP	MBP	HBP
32°C / 90°F	fan 3m/s	n/a	n/a
38°C / 100°F	fan 3m/s	n/a	n/a
43°C / 110°F	fan 3m/s	n/a	n/a

Operation pressure range

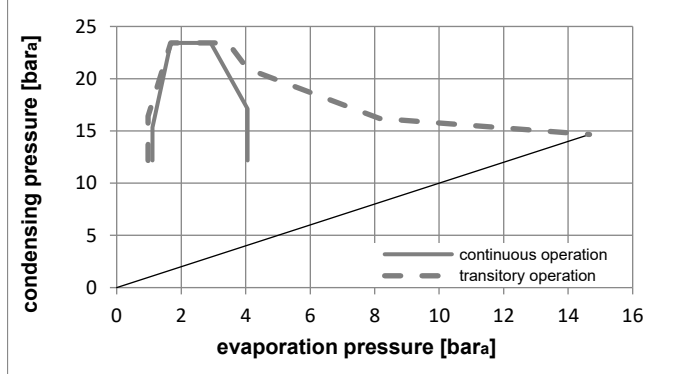
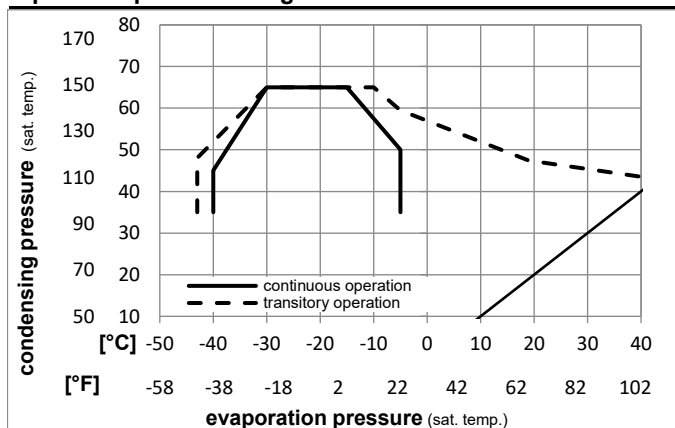

Components

a2	relay	117U7003
c	start capacitor (80µF)	117U5015
b	plastic cover	103N2010
d	cord relief	103N1010

Alternative components

b	plastic cover	103N2011
---	---------------	----------

Technical Data

Compressor



Model

Designation	NLE12.6CNL 220-240V/50Hz	Conf. 1	Sales code: 105H6378
-------------	---------------------------------	---------	-----------------------------

Optimization + standard conditions

220-240V/50Hz 1~, CSIR, fan 3m/s, VDE, CCC

	Evaporating pressure (saturation temperature)				Condensing pressure (saturation temperature)						Power consumption			ASHRAE LBP
	pe	pc	RGT	Tliq	Cooling capacity			COP	EER	P1	I	Ref. mass flow		
	[°C]	[°C]	[°C]	[°C]	[W]	[Btu/h]	[kcal/h]	[W/W]	[Btu/Wh]	[kcal/Wh]	[W]	[A]	[kg/h]	
	-23,3	54,4	32,2	32,2	609,8	2083	524,8	1,62	5,55	1,40	375,5	2,24	6,18	ASHRAE LBP
	[-10]	130	90	90										
	-25	55	32	55	459,7	1570	395,6	1,27	4,33	1,09	362,2	2,19	5,72	cecomaf LBP
	[-13]	131	89,6	131										
	-35	40	20	40	354,2	1210	304,8	1,33	4,55	1,15	265,6	1,87	4,05	EN12900 LBP
	[-31]	104	68	104										
	-23,3	48,9	4,44	48,9	493,6	1686	424,8	1,36	4,64	1,17	363,1	2,20	6,84	ARI540 LBP
	[-10]	120	40	120										
	-23,3	40,6	32,2	32,2	659,7	2253	567,8	1,91	6,53	1,65	345,0	2,13	6,68	AHAM LBP
	[-10]	105	90	90										
	-35	45	32	45	338,9	1157	291,6	1,25	4,28	1,08	270,4	1,89	3,80	opt
	[-31]	113	89,6	113										

Performance tables

220-240V/50Hz 1~, CSIR, fan 3m/s, VDE, CCC

	pe	Cooling capacity			COP	EER	P1	I	m		
	[°C]	[°F]	[W]	[Btu/h]	[kcal/h]	[W/W]	[Btu/Wh]	[kcal/Wh]	[W]	[A]	[kg/h]
[°C / °F]	-40	-40	258,9	884	222,8	1,11	3,78	0,95	233,9	1,78	2,89
cond. pressure	-35	-31	338,9	1157	291,6	1,25	4,28	1,08	270,4	1,89	3,80
pc= 45/113	-30	-22	430,1	1469	370,2	1,41	4,80	1,21	306,1	2,00	4,83
return gas temp.	-25	-13	536,4	1832	461,6	1,57	5,36	1,35	341,9	2,12	6,05
RGT= 32/90	-20	-4	661,6	2259	569,4	1,75	5,97	1,50	378,6	2,26	7,49
liquid temp	-15	5	809,3	2764	696,5	1,94	6,63	1,67	417,1	2,41	9,21
Tliq= 45/113	-5	23	1187,9	4057	1022,3	2,36	8,07	2,03	503,0	2,78	13,68
[°C / °F]	-40	-40	215,7	737	185,7	0,91	3,09	0,78	238,1	1,77	2,66
cond. pressure	-35	-31	287,2	981	247,2	1,03	3,52	0,89	279,0	1,90	3,55
pc= 55/131	-30	-22	367,3	1254	316,1	1,15	3,92	0,99	320,1	2,04	4,56
return gas temp	-25	-13	459,7	1570	395,6	1,27	4,33	1,09	362,2	2,19	5,72
RGT= 32/90	-20	-4	568,3	1941	489,1	1,40	4,78	1,20	406,1	2,36	7,11
liquid temp	-15	5	696,7	2379	599,6	1,54	5,25	1,32	452,8	2,55	8,76
Tliq= 55/131	-5	23	1028,4	3512	885,1	1,84	6,30	1,59	557,8	3,00	13,10

Technical Data

Compressor



Model

Designation	NLE12.6CNL 220-240V/50Hz	Conf. 2	Sales code:	105H6378
-------------	---------------------------------	----------------	-------------	-----------------

Configuration

Motorconfiguration	RSIR
Power supply (nominal)	220-240V/50Hz 1~
Refrigerant	R290
Application	LBP
Voltage range	198-254V
Starting torque	LST
Approvals	VDE CCC

Electrical accessories / wiring diagram

RSIR

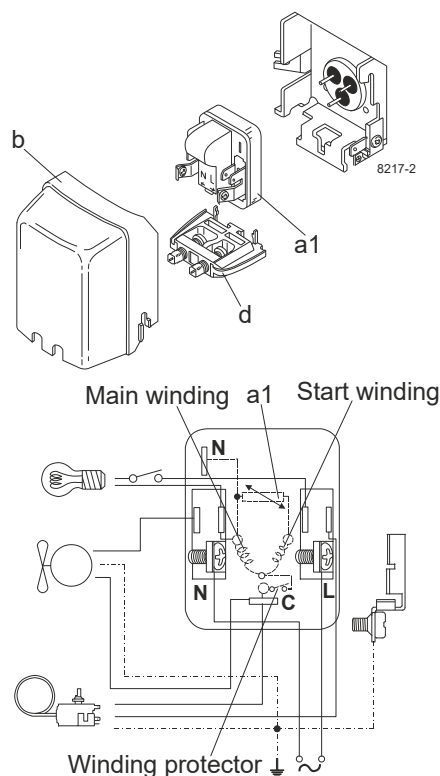

Ambient temperatures / system cooling

Ambient temperature min.:	10°C / 50°F
Ambient temperature max.:	43°C / 110°F

System cooling (n/a: outside limits)			
T ambient	LBP	MBP	HBP
32°C / 90°F	fan 3m/s	n/a	n/a
38°C / 100°F	fan 3m/s	n/a	n/a
43°C / 110°F	fan 3m/s	n/a	n/a

Operation pressure range

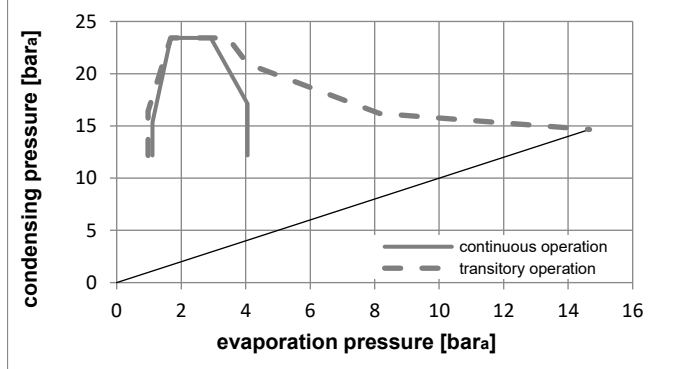
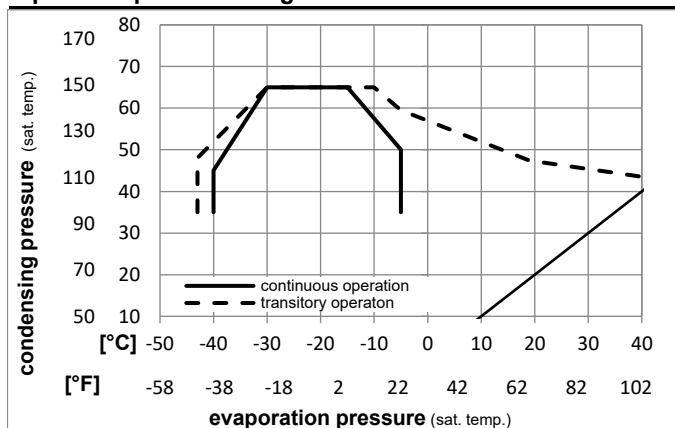

Components

a1	e-PTC starter (220V, 250hm, 4.8mm)	103N0050
b	plastic cover	103N2010
d	cord relief	103N1010

Alternative components

b	plastic cover	103N2011
---	---------------	----------

Technical Data

Compressor



Model

Designation	NLE12.6CNL 220-240V/50Hz	Conf. 2	Sales code:	105H6378
-------------	---------------------------------	----------------	-------------	-----------------

Optimization + standard conditions

220-240V/50Hz 1~, RSIR, fan 3m/s, VDE, CCC

	Evaporating pressure (saturation temperature)				Condensing pressure (saturation temperature)						Power consumption			ASHRAE LBP
	pe	pc	RGT	Tliq	Cooling capacity			COP	EER	P1	I	Ref. mass flow		
	[°C]	[°C]	[°C]	[°C]	[W]	[Btu/h]	[kcal/h]	[W/W]	[Btu/Wh]	[kcal/Wh]	[W]	[A]	[kg/h]	
	-23,3	54,4	32,2	32,2	609,8	2083	524,8	1,62	5,55	1,40	375,5	2,24	6,18	ASHRAE LBP
	[-10]	130	90	90										
	-25	55	32	55	459,7	1570	395,6	1,27	4,33	1,09	362,2	2,19	5,72	cecomaf LBP
	[-13]	131	89,6	131										
	-35	40	20	40	354,2	1210	304,8	1,33	4,55	1,15	265,6	1,87	4,05	EN12900 LBP
	[-31]	104	68	104										
	-23,3	48,9	4,44	48,9	493,6	1686	424,8	1,36	4,64	1,17	363,1	2,20	6,84	ARI540 LBP
	[-10]	120	40	120										
	-23,3	40,6	32,2	32,2	659,7	2253	567,8	1,91	6,53	1,65	345,0	2,13	6,68	AHAM LBP
	[-10]	105	90	90										
	-35	45	32	45	338,9	1157	291,6	1,25	4,28	1,08	270,4	1,89	3,80	opt
	[-31]	113	89,6	113										

Performance tables

220-240V/50Hz 1~, RSIR, fan 3m/s, VDE, CCC

	pe	Cooling capacity			COP	EER	P1	I	m		
	[°C]	[°F]	[W]	[Btu/h]	[kcal/h]	[W/W]	[Btu/Wh]	[kcal/Wh]	[W]	[A]	[kg/h]
[°C / °F]	-40	-40	258,9	884	222,8	1,11	3,78	0,95	233,9	1,78	2,89
cond. pressure	-35	-31	338,9	1157	291,6	1,25	4,28	1,08	270,4	1,89	3,80
pc= 45/113	-30	-22	430,1	1469	370,2	1,41	4,80	1,21	306,1	2,00	4,83
return gas temp.	-25	-13	536,4	1832	461,6	1,57	5,36	1,35	341,9	2,12	6,05
RGT= 32/90	-20	-4	661,6	2259	569,4	1,75	5,97	1,50	378,6	2,26	7,49
liquid temp	-15	5	809,3	2764	696,5	1,94	6,63	1,67	417,1	2,41	9,21
Tliq= 45/113	-5	23	1187,9	4057	1022,3	2,36	8,07	2,03	503,0	2,78	13,68
[°C / °F]	-40	-40	215,7	737	185,7	0,91	3,09	0,78	238,1	1,77	2,66
cond. pressure	-35	-31	287,2	981	247,2	1,03	3,52	0,89	279,0	1,90	3,55
pc= 55/131	-30	-22	367,3	1254	316,1	1,15	3,92	0,99	320,1	2,04	4,56
return gas temp.	-25	-13	459,7	1570	395,6	1,27	4,33	1,09	362,2	2,19	5,72
RGT= 32/90	-20	-4	568,3	1941	489,1	1,40	4,78	1,20	406,1	2,36	7,11
liquid temp	-15	5	696,7	2379	599,6	1,54	5,25	1,32	452,8	2,55	8,76
Tliq= 55/131	-5	23	1028,4	3512	885,1	1,84	6,30	1,59	557,8	3,00	13,10

Technical Data

Compressor



Model

Designation	NLE12.6CNL 220-240V/50Hz	Conf. 3	Sales code:	105H6378
-------------	---------------------------------	----------------	-------------	-----------------

Configuration

Motorconfiguration	RSCR
Power supply (nominal)	220-240V/50Hz 1~
Refrigerant	R290
Application	LBP
Voltage range	198-254V
Starting torque	LST
Approvals	VDE CCC

Electrical accessories / wiring diagram

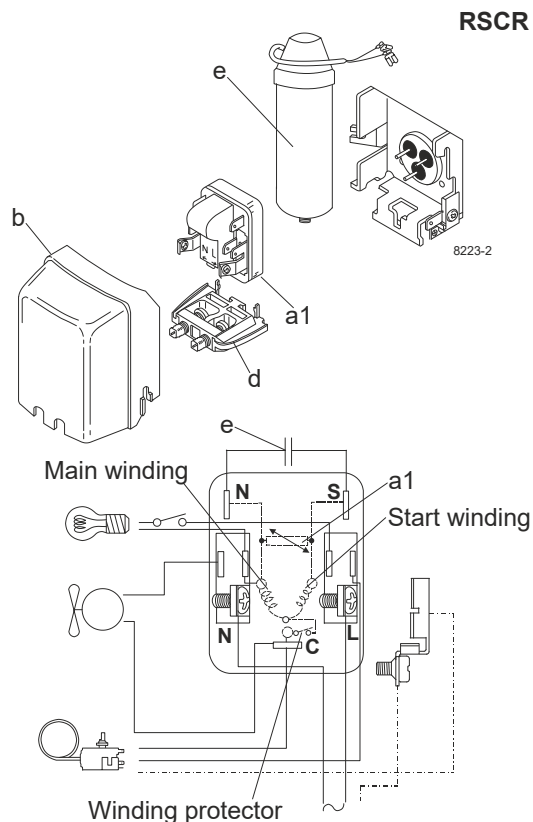

Ambient temperatures / system cooling

Ambient temperature min.:	10°C / 50°F
Ambient temperature max.:	43°C / 110°F

System cooling (n/a: outside limits)			
T ambient	LBP	MBP	HBP
32°C / 90°F	fan 3m/s	n/a	n/a
38°C / 100°F	fan 3m/s	n/a	n/a
43°C / 110°F	fan 3m/s	n/a	n/a

Operation pressure range

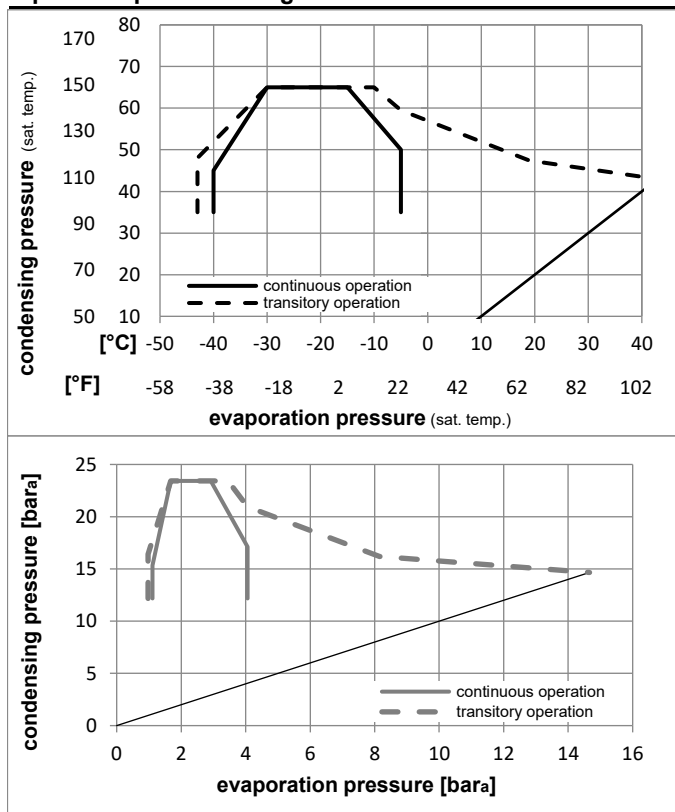

Components

a1	e-PTC starter (220V, 250hm, 4.8mm)	103N0050
e	run capacitor (4μF, 4.8mm)	117-7119
b	plastic cover	103N2010
d	cord relief	103N1010
	bracket for run capacitor	117-0300
	screw M4x8mm	117-0301

Alternative components

b	plastic cover	103N2011
---	---------------	----------

Technical Data

Compressor



Model

Designation	NLE12.6CNL 220-240V/50Hz	Conf. 3	Sales code: 105H6378
-------------	---------------------------------	---------	-----------------------------

Optimization + standard conditions

220-240V/50Hz 1~, RSCR, fan 3m/s, VDE, CCC

	Evaporating pressure (saturation temperature)				Condensing pressure (saturation temperature)						Power consumption			ASHRAE LBP
	pe	pc	RGT	Tliq	Cooling capacity			COP	EER	P1	I	Ref. mass flow		
	[°C]	[°C]	[°C]	[°C]	[W]	[Btu/h]	[kcal/h]	[W/W]	[Btu/Wh]	[kcal/Wh]	[W]	[A]	[kg/h]	
	-23,3	54,4	32,2	32,2	613,3	2095	527,8	1,69	5,77	1,45	363,0	2,17	6,21	ASHRAE LBP
	[-10]	130	90	90										
	-25	55	32	55	462,1	1578	397,7	1,32	4,51	1,14	350,2	2,12	5,75	cecomaf LBP
	[-13]	131	89,6	131										
	-35	40	20	40	352,8	1205	303,6	1,39	4,76	1,20	253,2	1,79	4,03	EN12900 LBP
	[-31]	104	68	104										
	-23,3	48,9	4,44	48,9	496,5	1696	427,3	1,41	4,83	1,22	351,0	2,13	6,88	ARI540 LBP
	[-10]	120	40	120										
	-23,3	40,6	32,2	32,2	663,8	2267	571,2	1,99	6,79	1,71	333,7	2,06	6,72	AHAM LBP
	[-10]	105	90	90										
	-35	45	32	45	337,5	1153	290,5	1,31	4,47	1,13	257,7	1,80	3,78	opt
	[-31]	113	89,6	113										

Performance tables

220-240V/50Hz 1~, RSCR, fan 3m/s, VDE, CCC

	pe	Cooling capacity			COP	EER	P1	I	m		
	[°C]	[°F]	[W]	[Btu/h]	[kcal/h]	[W/W]	[Btu/Wh]	[kcal/Wh]	[W]	[A]	[kg/h]
[°C / °F]	-40	-40	255,5	873	219,9	1,18	4,02	1,01	217,0	1,66	2,86
cond. pressure	-35	-31	337,5	1153	290,5	1,31	4,47	1,13	257,7	1,80	3,78
pc= 45/113	-30	-22	430,9	1472	370,8	1,46	4,99	1,26	295,1	1,93	4,84
return gas temp.	-25	-13	539,3	1842	464,1	1,63	5,57	1,40	330,6	2,05	6,08
RGT= 32/90	-20	-4	666,1	2275	573,3	1,82	6,22	1,57	365,5	2,18	7,54
liquid temp	-15	5	815,0	2783	701,4	2,03	6,94	1,75	401,0	2,32	9,27
Tliq= 45/113	-5	23	1193,1	4075	1026,8	2,49	8,51	2,14	479,1	2,65	13,74
[°C / °F]	-40	-40	213,2	728	183,5	0,97	3,30	0,83	220,9	1,65	2,63
cond. pressure	-35	-31	286,1	977	246,3	1,08	3,67	0,93	265,9	1,81	3,54
pc= 55/131	-30	-22	367,9	1257	316,6	1,19	4,07	1,03	308,6	1,97	4,56
return gas temp.	-25	-13	462,1	1578	397,7	1,32	4,51	1,14	350,2	2,12	5,75
RGT= 32/90	-20	-4	572,1	1954	492,4	1,46	4,98	1,26	392,0	2,28	7,16
liquid temp	-15	5	701,6	2396	603,8	1,61	5,51	1,39	435,2	2,45	8,82
Tliq= 55/131	-5	23	1033,1	3528	889,1	1,94	6,64	1,67	531,4	2,86	13,16