

Technical Data

Compressor



Model

Designation	DLE6.5CN	220-240V/50Hz 1~	Sales code:	102H4765
-------------	-----------------	-------------------------	-------------	-----------------

Compressor design

Oil type	Polyolester	Refrigerant(s)	R290
Oil viscosity	32cSt	Displacement	6,5cm ³ / 0,4cu.in
Oil quantity	221cm ³ / 7,5fl.oz	Compressors on pallet	100
Refr. charge - tech. limit	150g / 5,3oz		
Free gas volume comp.	1325cm ³ / 44,8fl.oz		
Weight	8,55kg / 18,8lbs		
Motor protection	1# internal		
Winding resistance main	13,6Ω (at 25°C)		
Winding resistance aux	18,5Ω (at 25°C)		
Max. winding temp.	125°C / 257°F		
Max. discharge temp.	130°C / 266°F		



General - Configurations with DLE6.5CN

	Conf. 1	Conf. 2	Conf. 3
Motorconfiguration	CSIR	RSIR	RSCR
Power supply (nominal)	220-240V/50Hz	220-240V/50Hz	220-240V/50Hz
Number of phases	1	1	1
Voltage range	198-254V	198-254V	198-254V
Approvals	VDE, CCC, EAC	VDE, CCC, EAC	VDE, CCC, EAC
Starting torque	HST	LST	LST
Note	- / -		

Applications with DLE6.5CN

	Conf. 1	Conf. 2	Conf. 3
Refrigerant	R290	R290	R290
Application	LBP+MBP	LBP+MBP	LBP+MBP
System cooling	fan 3m/s	fan 3m/s	fan 3m/s
Hot gas defrost	OK	OK	OK
Long interval pull down	OK	OK	OK

Electrical data - Configurations with DLE6.5CN

	Conf. 1	Conf. 2	Conf. 3
Starting device type	relay	PTC	PTC
Run capacitor	-/-	-/-	5μF
Start capacitor	80μF	-/-	-/-
LRA (locked rotor amps / 4s)	9,3A	7,3A	7,3A
RLA (rated load amps / 1s)	1,47A	1,47A	1,32A
Cut in current	9,3A	11,5A	11,5A
IP class	21	21	21



Model

Designation	DLE6.5CN	220-240V/50Hz 1~	Sales code:	102H4765
-------------	-----------------	------------------	-------------	-----------------

Compressor dimensions

Housing	A Height	174mm / 6,85in
	B Height	168mm / 6,61in
	C Length shell	183mm / 7,2in
	D Length w. cover	232mm / 9,13in
	E Width	156mm / 6,14in

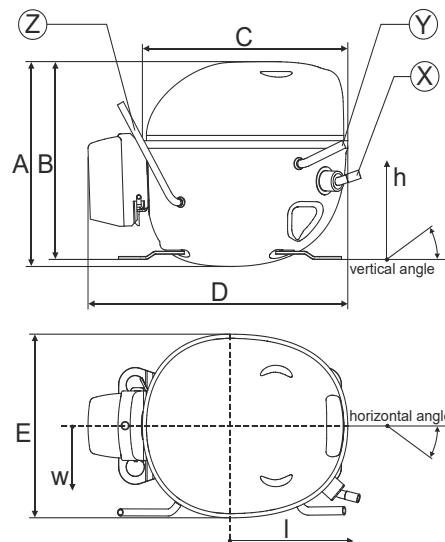

Connectors		Suction	Discharge	Process
		X	Y	Z
Diameter	[mm]	øi 8,11-8,29	øi 6,11-6,29	øi 6,1-6,3
	(i:inside, o:outside) [in]	øi 0,32-0,33	øi 0,24-0,25	øi 0,24-0,25
Material		copper	copper	copper
Horizontal angle	±2°	10°	0°	0°
Vertical angle	±2°	18°	25°	119°
Position l/h/w	[mm]	135/77/67	98/96/72	-98/133/73
	[in]	5,3/3/2,6	3,8/3,8/2,8	-3,9/5,2/2,9
Straight tube l.	[mm]	12	12	12
	[in]	0,5	0,5	0,5

Compressor fixation

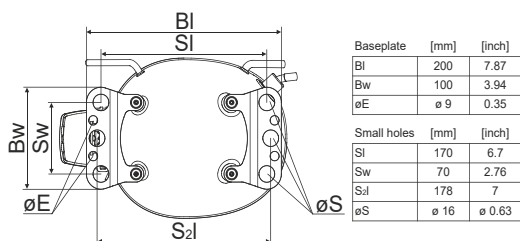

Bolt joint

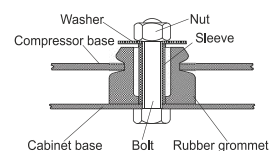

Snap-on

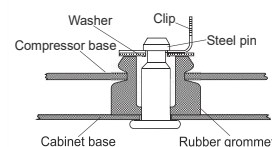

Mounting accessories

	one comp.	multi pack
Bolt joint M6 ø16mm	118-1917	118-1918
Bolt joint ø1/4" ø16mm	118-1946	
Snap-on ø7,3 ø16mm	118-1947	118-1919

Technical Data

Compressor



Model

Designation	DLE6.5CN	220-240V/50Hz	Conf. 1	Sales code:	102H4765
-------------	-----------------	----------------------	----------------	-------------	-----------------

Configuration

Motorconfiguration	CSIR
Power supply (nominal)	220-240V/50Hz 1~
Refrigerant	R290
Application	LBP+MBP
Voltage range	198-254V
Starting torque	HST
Approvals	VDE
	CCC
	EAC

Electrical accessories / wiring diagram

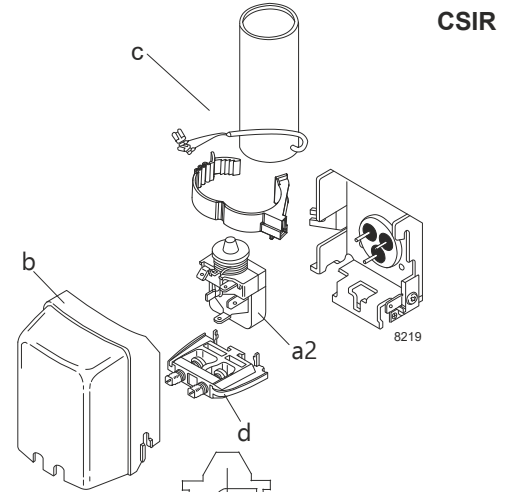

Ambient temperatures / system cooling

Ambient temperature min.:	10°C / 50°F
Ambient temperature max.:	43°C / 110°F

System cooling (n/a: outside limits)			
T ambient	LBP	MBP	HBP
32°C / 90°F	fan 3m/s	fan 3m/s	n/a
38°C / 100°F	fan 3m/s	fan 3m/s	n/a
43°C / 110°F	fan 3m/s	fan 3m/s	n/a

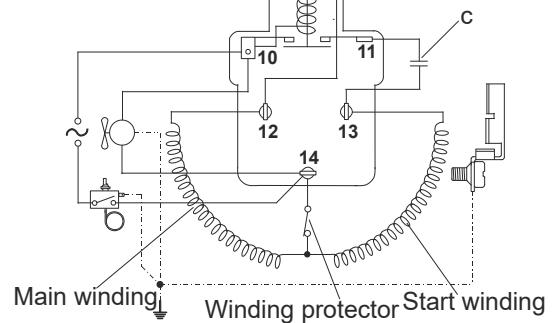

Operation pressure range

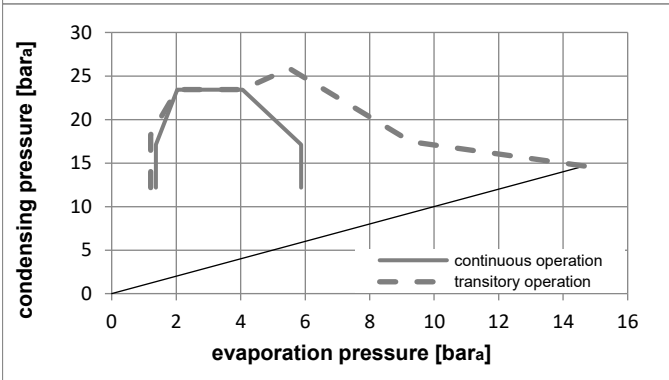
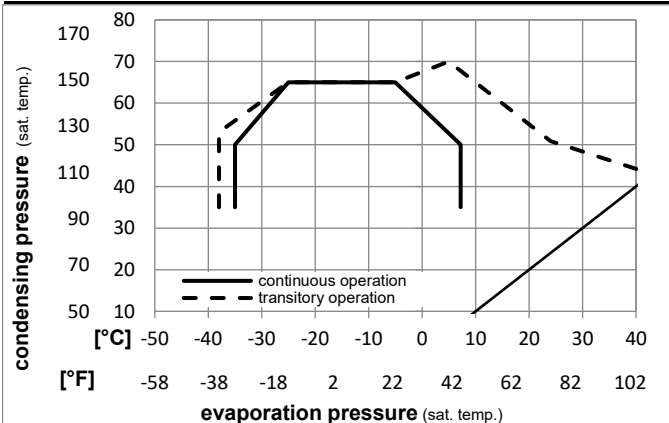

Components

a2	current relay	117U7016
c	start capacitor (80µF)	117U5015
b	plastic cover	103N0491
d	cord relief	103N1010

Technical Data

Compressor



Model

Designation	DLE6.5CN	220-240V/50Hz	Conf. 1	Sales code:	102H4765
-------------	-----------------	----------------------	----------------	-------------	-----------------

Optimization + standard conditions

220-240V/50Hz 1~, CSIR, fan 3m/s, VDE, CCC, EAC

	Evaporating pressure (saturation temperature)				Condensing pressure (saturation temperature)						Power consumption			ASHRAE LBP
	pe	pc	RGT	Tliq	Cooling capacity			COP	EER	P1	I	Ref. mass flow		
	[°C]	[°C]	[°C]	[°C]	[W]	[Btu/h]	[kcal/h]	[W/W]	[Btu/Wh]	[kcal/Wh]	[W]	[A]	[kg/h]	
	-23,3	54,4	32,2	32,2	314,7	1075	270,8	1,53	5,22	1,32	205,9	1,27	3,19	ASHRAE LBP
	[-10]	130	90	90										
	-25	55	32	55	235,9	806	203,1	1,19	4,07	1,02	198,2	1,25	2,94	cecomaf LBP
	[-13]	131	89,6	131										
	-35	40	20	40	172,3	589	148,3	1,17	4,00	1,01	147,0	1,09	1,97	EN12900 LBP
	[-31]	104	68	104										
	-6,66	54,4	35	46,1	548,9	1875	472,4	1,92	6,56	1,65	285,6	1,58	6,26	ASHRAE MBP
	[20]	130	95	115										
	-10	55	32	55	436,7	1491	375,8	1,61	5,50	1,38	271,4	1,52	5,52	cecomaf MBP
	[14]	131	89,6	131										
	-10	45	20	45	483,4	1651	416,0	1,99	6,79	1,71	243,3	1,41	5,94	EN12900 MBP
	[14]	113	68	113										

Performance tables

220-240V/50Hz 1~, CSIR, fan 3m/s, VDE, CCC, EAC

	pe	Cooling capacity			COP	EER	P1	I	m		
	[°C]	[°F]	[W]	[Btu/h]	[kcal/h]	[W/W]	[Btu/Wh]	[kcal/Wh]	[W]	[A]	[kg/h]
[°C / °F]	-35	-31	165,1	564	142,1	1,09	3,74	0,94	150,8	1,10	1,85
cond. pressure	-25	-13	272,1	929	234,2	1,45	4,96	1,25	187,4	1,21	3,07
pc= 45/113	-15	5	413,8	1413	356,1	1,84	6,28	1,58	225,0	1,34	4,71
return gas temp.	-10	14	503,3	1719	433,1	2,07	7,06	1,78	243,3	1,41	5,76
RGT= 32/90	-5	23	608,1	2077	523,4	2,33	7,97	2,01	260,7	1,48	7,00
liquid temp	0	32	730,7	2495	628,8	2,64	9,01	2,27	277,0	1,55	8,47
Tliq= 45/113	7,2	45	942,6	3219	811,2	3,17	10,81	2,73	297,7	1,63	11,07
[°C / °F]	-35	-31	135,3	462	116,5	0,90	3,07	0,77	150,8	1,10	1,67
cond. pressure	-25	-13	235,9	806	203,1	1,19	4,07	1,02	198,2	1,25	2,94
pc= 55/131	-15	5	360,2	1230	309,9	1,46	4,98	1,25	247,2	1,43	4,53
return gas temp	-10	14	436,7	1491	375,8	1,61	5,50	1,38	271,4	1,52	5,52
RGT= 32/90	-5	23	525,9	1796	452,6	1,78	6,09	1,53	295,0	1,62	6,70
liquid temp	0	32	629,9	2151	542,1	1,98	6,77	1,71	317,6	1,71	8,09
Tliq= 55/131	7,2	45	810,4	2768	697,4	2,33	7,96	2,01	347,6	1,85	10,56

Technical Data

Compressor



Model

Designation	DLE6.5CN	220-240V/50Hz	Conf. 2	Sales code:	102H4765
-------------	-----------------	----------------------	----------------	-------------	-----------------

Configuration

Motorconfiguration	RSIR
Power supply (nominal)	220-240V/50Hz 1~
Refrigerant	R290
Application	LBP+MBP
Voltage range	198-254V
Starting torque	LST
Approvals	VDE
	CCC
	EAC

Electrical accessories / wiring diagram

RSIR

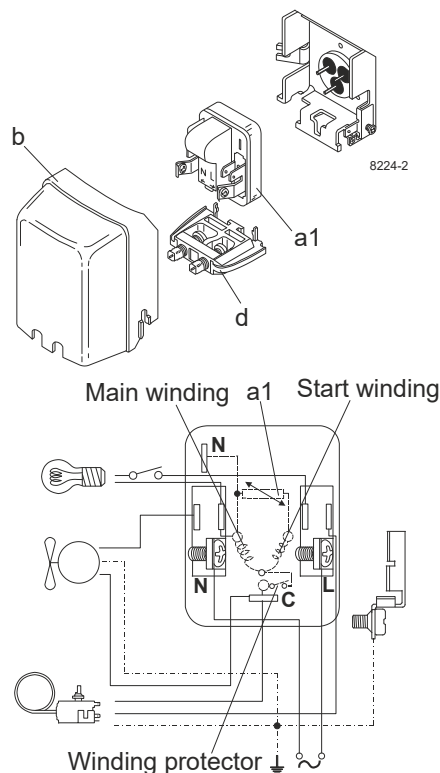

Ambient temperatures / system cooling

Ambient temperature min.:	10°C / 50°F
Ambient temperature max.:	43°C / 110°F

System cooling (n/a: outside limits)			
T ambient	LBP	MBP	HBP
32°C / 90°F	fan 3m/s	fan 3m/s	n/a
38°C / 100°F	fan 3m/s	fan 3m/s	n/a
43°C / 110°F	fan 3m/s	fan 3m/s	n/a

Operation pressure range

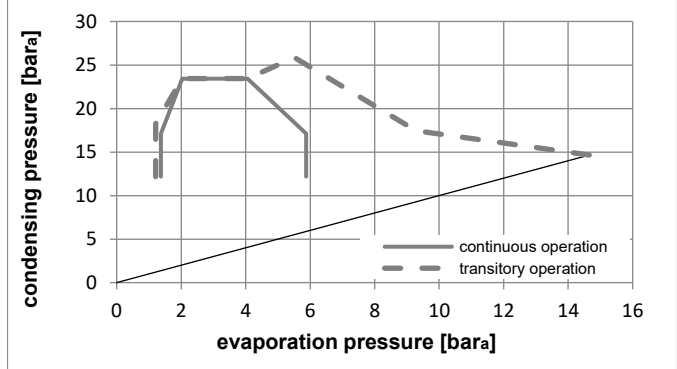
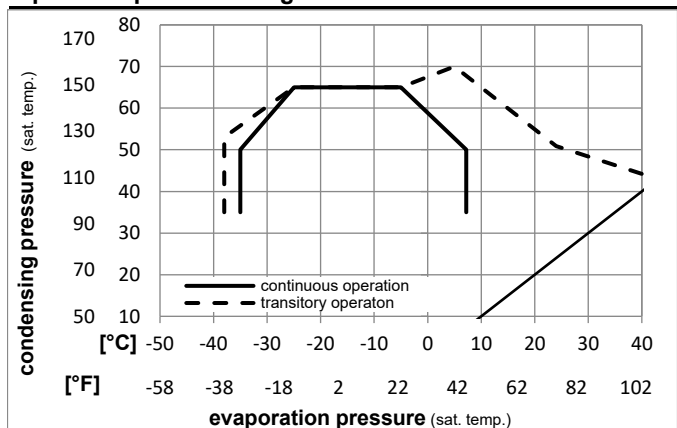

Components

a1	e-PTC starter (220V, 250hm, 4.8mm)	103N0050
b	plastic cover	103N0491
d	cord relief	103N1010

Technical Data

Compressor



Model

Designation	DLE6.5CN	220-240V/50Hz	Conf. 2	Sales code:	102H4765
-------------	-----------------	----------------------	----------------	-------------	-----------------

Optimization + standard conditions

220-240V/50Hz 1~, RSIR, fan 3m/s, VDE, CCC, EAC

	Evaporating pressure (saturation temperature)				Condensing pressure (saturation temperature)			Return gas temp.		Liquid temp.		Cooling capacity			COP	EER	Power consumption			ASHRAE LBP
	pe	pc	RGT	Tliq	[W]	[Btu/h]	[kcal/h]	[W/W]	[Btu/Wh]	[kcal/Wh]	P1	I	m	[W]	[A]	[kg/h]	ASHRAE LBP			
[°C]	-23,3	54,4	32,2	32,2	314,7	1075	270,8	1,53	5,22	1,32	205,9	1,27	3,19							
[°F]	-10	130	90	90																
[°C]	-25	55	32	55	235,9	806	203,1	1,19	4,07	1,02	198,2	1,25	2,94							
[°F]	-13	131	89,6	131																
[°C]	-35	40	20	40	172,3	589	148,3	1,17	4,00	1,01	147,0	1,09	1,97							
[°F]	-31	104	68	104																
[°C]	-6,66	54,4	35	46,1	548,9	1875	472,4	1,92	6,56	1,65	285,6	1,58	6,26							
[°F]	20	130	95	115																
[°C]	-10	55	32	55	436,7	1491	375,8	1,61	5,50	1,38	271,4	1,52	5,52							
[°F]	14	131	89,6	131																
[°C]	-10	45	20	45	483,4	1651	416,0	1,99	6,79	1,71	243,3	1,41	5,94							
[°F]	14	113	68	113																

Performance tables

220-240V/50Hz 1~, RSIR, fan 3m/s, VDE, CCC, EAC

	pe	Cooling capacity			COP			EER			P1	I	m
	[°C]	[°F]	[W]	[Btu/h]	[kcal/h]	[W/W]	[Btu/Wh]	[kcal/Wh]	[W]	[A]	[kg/h]		
[°C / °F]	-35	-31	165,1	564	142,1	1,09	3,74	0,94	150,8	1,10	1,85		
cond. pressure	-25	-13	272,1	929	234,2	1,45	4,96	1,25	187,4	1,21	3,07		
pc= 45/113	-15	5	413,8	1413	356,1	1,84	6,28	1,58	225,0	1,34	4,71		
return gas temp.	-10	14	503,3	1719	433,1	2,07	7,06	1,78	243,3	1,41	5,76		
RGT= 32/90	-5	23	608,1	2077	523,4	2,33	7,97	2,01	260,7	1,48	7,00		
liquid temp	0	32	730,7	2495	628,8	2,64	9,01	2,27	277,0	1,55	8,47		
Tliq= 45/113	7,2	45	942,6	3219	811,2	3,17	10,81	2,73	297,7	1,63	11,07		
[°C / °F]	-35	-31	135,3	462	116,5	0,90	3,07	0,77	150,8	1,10	1,67		
cond. pressure	-25	-13	235,9	806	203,1	1,19	4,07	1,02	198,2	1,25	2,94		
pc= 55/131	-15	5	360,2	1230	309,9	1,46	4,98	1,25	247,2	1,43	4,53		
return gas temp.	-10	14	436,7	1491	375,8	1,61	5,50	1,38	271,4	1,52	5,52		
RGT= 32/90	-5	23	525,9	1796	452,6	1,78	6,09	1,53	295,0	1,62	6,70		
liquid temp	0	32	629,9	2151	542,1	1,98	6,77	1,71	317,6	1,71	8,09		
Tliq= 55/131	7,2	45	810,4	2768	697,4	2,33	7,96	2,01	347,6	1,85	10,56		

Technical Data

Compressor



Model

Designation	DLE6.5CN	220-240V/50Hz	Conf. 3	Sales code:	102H4765
-------------	-----------------	----------------------	----------------	-------------	-----------------

Configuration

Motorconfiguration	RSCR
Power supply (nominal)	220-240V/50Hz 1~
Refrigerant	R290
Application	LBP+MBP
Voltage range	198-254V
Starting torque	LST
Approvals	VDE
	CCC
	EAC

Electrical accessories / wiring diagram

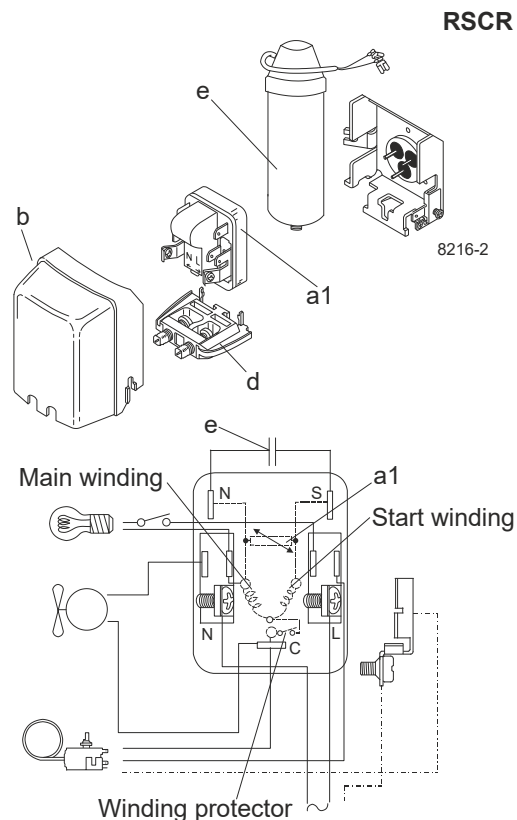

Ambient temperatures / system cooling

Ambient temperature min.:	10°C / 50°F
Ambient temperature max.:	43°C / 110°F

System cooling (n/a: outside limits)			
T ambient	LBP	MBP	HBP
32°C / 90°F	fan 3m/s	fan 3m/s	n/a
38°C / 100°F	fan 3m/s	fan 3m/s	n/a
43°C / 110°F	fan 3m/s	fan 3m/s	n/a

Operation pressure range

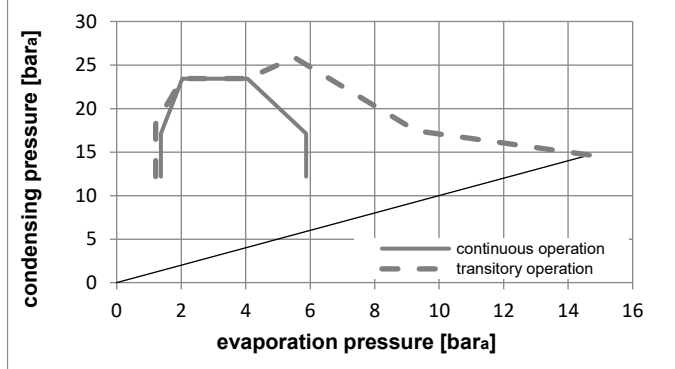
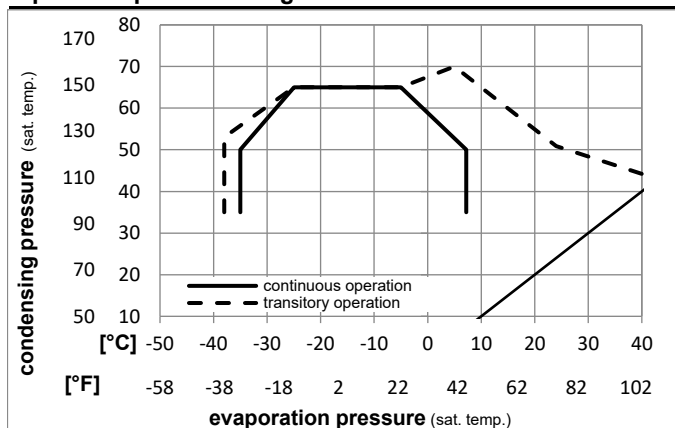

Components

a1	e-PTC starter (220V, 250hm, 4.8mm)	103N0050
e	run capacitor (5μF, 4.8mm)	117-7129
b	plastic cover	103N0491
d	cord relief	103N1010
	bracket for run capacitor	117-0300
	screw M4x8mm	117-0301

Technical Data

Compressor



Model

Designation	DLE6.5CN	220-240V/50Hz	Conf. 3	Sales code:	102H4765
-------------	-----------------	----------------------	----------------	-------------	-----------------

Optimization + standard conditions

220-240V/50Hz 1~, RSCR, fan 3m/s, VDE, CCC, EAC

	Evaporating pressure (saturation temperature)				Condensing pressure (saturation temperature)			Return gas temp.			Liquid temp.			Cooling capacity			COP	EER	Power consumption			ASHRAE LBP
	pe	pc	RGT	Tliq	[W]	[Btu/h]	[kcal/h]	[W/W]	[Btu/Wh]	[kcal/Wh]	P1	I	m	[W]	[A]	[kg/h]						
[°C]	-23,3	54,4	32,2	32,2	317,8	1085	273,5	1,65	5,65	1,42	192,2	1,18	3,22									
[°F]	-10	130	90	90																		
[°C]	-25	55	32	55	238,3	814	205,1	1,29	4,39	1,11	185,4	1,15	2,97								cecomaf LBP	
[°F]	-13	131	89,6	131																		
[°C]	-35	40	20	40	174,1	594	149,8	1,25	4,26	1,07	139,4	1,05	1,99								EN12900 LBP	
[°F]	-31	104	68	104																		
[°C]	-6,66	54,4	35	46,1	554,4	1893	477,1	2,12	7,22	1,82	262,1	1,44	6,32								ASHRAE MBP	
[°F]	20	130	95	115																		
[°C]	-10	55	32	55	441,1	1506	379,6	1,77	6,04	1,52	249,5	1,39	5,58								cecomaf MBP	
[°F]	14	131	89,6	131																		
[°C]	-10	45	20	45	488,2	1667	420,2	2,18	7,45	1,88	223,7	1,30	5,99								EN12900 MBP	
[°F]	14	113	68	113																		

Performance tables

220-240V/50Hz 1~, RSCR, fan 3m/s, VDE, CCC, EAC

	pe	Cooling capacity			COP			EER			P1	I	m
	[°C]	[°F]	[W]	[Btu/h]	[kcal/h]	[W/W]	[Btu/Wh]	[kcal/Wh]	[W]	[A]	[kg/h]		
[°C / °F]	-35	-31	166,8	570	143,5	1,17	3,98	1,00	143,1	1,06	1,87		
cond. pressure	-25	-13	274,8	939	236,5	1,56	5,34	1,35	175,8	1,13	3,10		
pc= 45/113	-15	5	417,9	1427	359,7	2,01	6,86	1,73	208,0	1,24	4,76		
return gas temp.	-10	14	508,3	1736	437,4	2,27	7,76	1,96	223,7	1,30	5,81		
RGT= 32/90	-5	23	614,2	2098	528,6	2,57	8,77	2,21	239,2	1,36	7,07		
liquid temp	0	32	738,0	2520	635,1	2,90	9,91	2,50	254,3	1,42	8,56		
Tliq= 45/113	7,2	45	952,0	3251	819,3	3,46	11,81	2,98	275,2	1,51	11,19		
[°C / °F]	-35	-31	136,7	467	117,6	0,96	3,27	0,82	142,9	1,04	1,69		
cond. pressure	-25	-13	238,3	814	205,1	1,29	4,39	1,11	185,4	1,15	2,97		
pc= 55/131	-15	5	363,8	1242	313,0	1,59	5,44	1,37	228,2	1,30	4,57		
return gas temp.	-10	14	441,1	1506	379,6	1,77	6,04	1,52	249,5	1,39	5,58		
RGT= 32/90	-5	23	531,1	1814	457,1	1,96	6,70	1,69	270,7	1,47	6,77		
liquid temp	0	32	636,2	2173	547,5	2,18	7,45	1,88	291,7	1,56	8,17		
Tliq= 55/131	7,2	45	818,5	2795	704,4	2,55	8,69	2,19	321,5	1,69	10,66		